



131 Seton Hill Dr., Floor 3B
Greensburg, PA 15601

March 16, 2015

Ms. Rosemary Chiavetta, Secretary
PA Public Utility Commission
P. O. Box 3265
Harrisburg, PA 17105-3265

RE: DOT AAR 361-452F
McAdoo Borough, Schuylkill County

Dear Ms. Chiavetta:

Enclosed is the application to the PUC for Verizon Pennsylvania LLC to add to an existing aerial crossing in McAdoo Borough, Schuylkill County, PA. To complete this work we must cross the Reading Blue Mountain & Northern Railroad in the public right-of way of E. Blaine Street, Crossing 361-452F.

All parties have been notified.

Sincerely

A handwritten signature in cursive script that reads "Deborah Delia".

Deborah Delia
Verizon Pennsylvania LLC

**BEFORE
PENNSYLVANIA PUBLIC UTILITY COMMISSION**

In re: Application of Verizon Pennsylvania LLC
for approval to add to an existing aerial crossing
in McAdoo Borough, Schuylkill County, PA.

Application _____

To complete this work, we must cross Reading Blue Mountain & Northern Railroad
in the public right-of-way of E. Blaine Street, Crossing 361-452F.

Pennsylvania Public Utility Commission:

- 1.) The name and address of the applicant are

Verizon Pennsylvania LLC
15 E. Montgomery Ave. 2nd Floor, Right of Way Dept.,
Pittsburgh, PA 15212.

- 2.) The name and address of applicant's attorney are,

Suzan D. Paiva
Assistant General Counsel
1717 Arch Street
3rd Floor
Philadelphia, Pennsylvania 19103

- 3.) Verizon Pennsylvania LLC wishes to add an aerial crossing in the Borough of McAdoo, Schuylkill County. To complete this work, we must cross Reading Blue Mountain & Northern Railroad in the public Right of Way of E. Blaine Street, Crossing # 361-452F. Proposed start date for this project is May 1, 2015.
- 4.) The proposed construction is an Fiber Optic Cable being attached to two (2) existing Verizon Pennsylvania LLC poles. Proposed completion date for this project is August 31, 2015.
- 5.) The public utilities, municipalities, corporations and property owners concerned in, or affected by the crossing alterations are identified in Exhibit "B" attached hereto.
- 6.) Verizon Pennsylvania LLC normal construction procedure includes the use of warning devices and flagmen when necessary, to maintain, as nearly as possible the normal flow of vehicular traffic. Estimated cost of the construction is \$10,000.00.
- 7.) Verizon Pennsylvania LLC will pay all costs of the proposed construction
- 8.) The alterations at this crossing are necessary for: Verizon Pennsylvania LLC to provide digital communication service to businesses in the area.

WHEREFORE, applicant, Verizon Pennsylvania LLC prays your Honorable Commission to approve the Application.

Respectfully submitted,

Deborah Delic
Verizon Pennsylvania LLC

1.36. Verification.

(a) Applications, petitions, formal complaints, motions and answers thereto containing an averment of fact not appearing of record in the action or containing a denial of fact shall be personally verified by a party thereto or by an authorized officer of the party if a corporation or association. Verification means a signed written statement of fact supported by oath or affirmation or made subject to the penalties of 18 Pa. C.S. §4904 (relating to unsworn falsification to authorities). If verification is required, notarization is not necessary.

(b) The Verification form should comply substantially with the following:

VERIFICATION

I, Gregory A. Jarrett, hereby state that the facts above set forth are true and correct (or are true and correct to the best of my knowledge, information and belief) and that I expect to be able to prove the same at a hearing held in this matter. I understand that the statements herein are made subject to the penalties of 18 Pa. C.S. § 4904 (relating to unsworn falsification to authorities).

Date:

3/16/15

(Signature)

Deborah Delic

EXHIBIT "A"

PUBLIC CROSSING
E. BLAINE ST # 361-452F
McADOO BOROUGH, PA

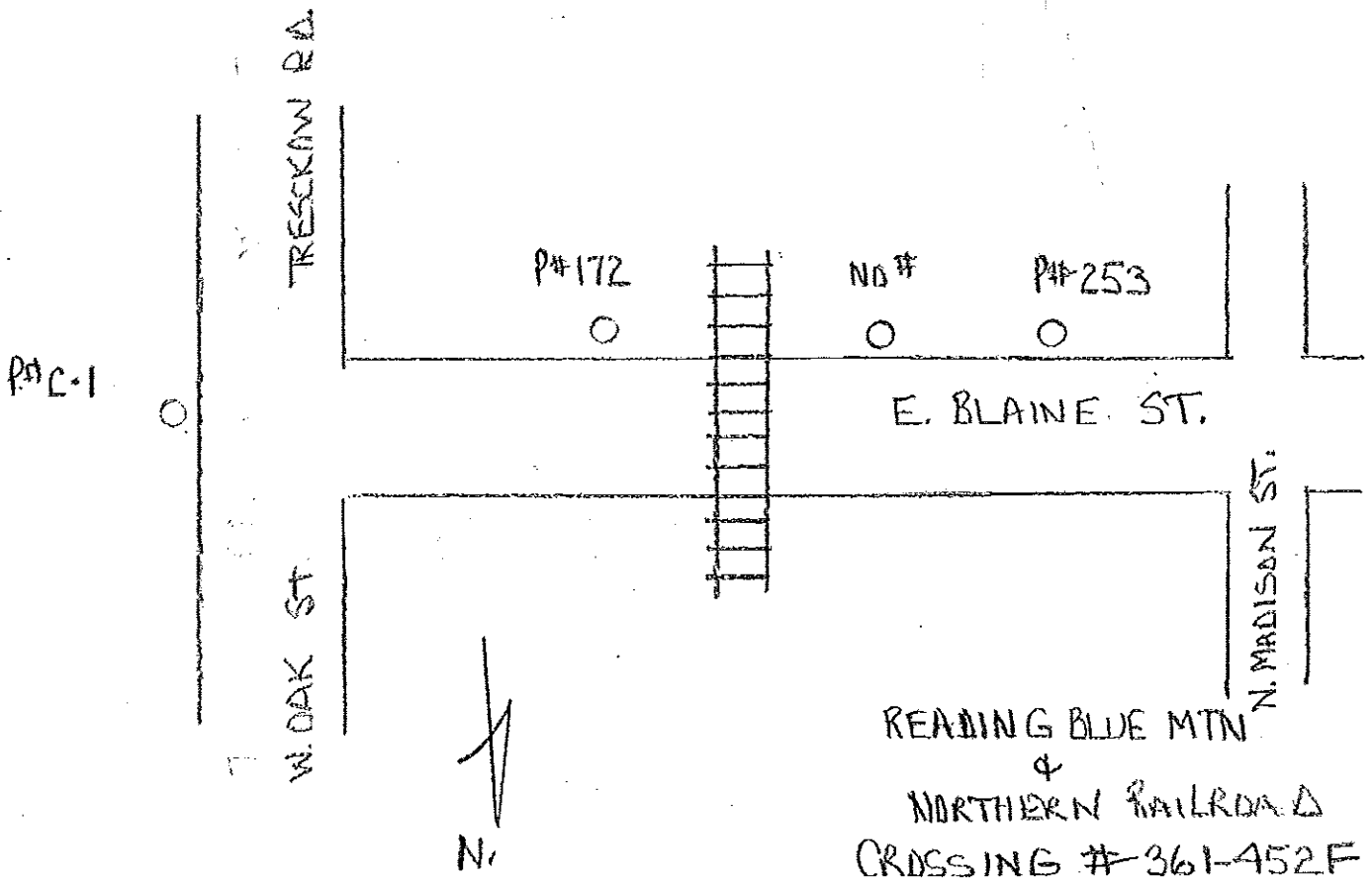
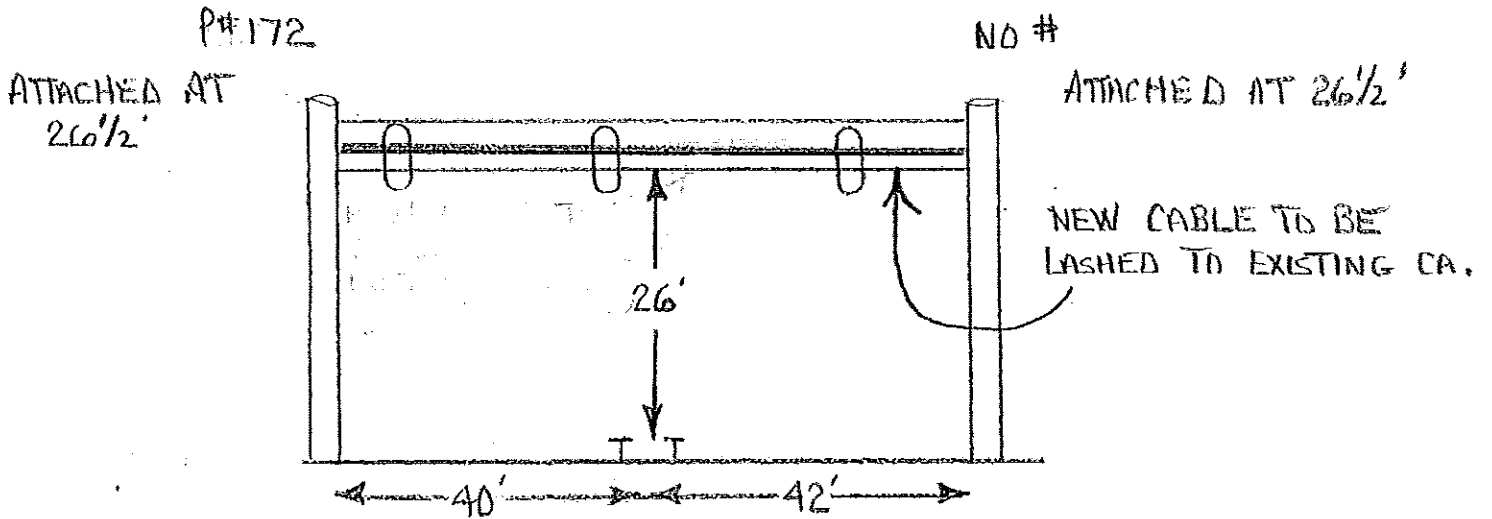

EXHIBIT "B"

The public utilities, municipalities, corporations, and property owners concerned in, or affected by, the crossing alterations are:

PennDOT Bureau of Design
Mark D. Chappell, PE CHIEF
Keystone Building – 7th Floor
P. O. Box 3362
Harrisburg, PA 17105-3362

Ms. Gina M. D'Alfonso
Assistant Counsel in Charge
Dept. of Transportation
Office of Chief Personnel
P. O. Box 8212
9th Floor
Harrisburg, PA 171005-8212

Schuylkill County Board of Commissioners
401 North Second Street
Pottsville, PA 17901

McAdoo Borough
23 N. Hancock Street
McAdoo, PA 18237

PennDOT District 5-0
District Executive
1002 Hamilton Street
Allentown, PA 18101

Rodney D. Bender, PE Manger
Public Utility Commission
Rail Safety Division
P. O. Box 3265
Harrisburg, PA 17105

PPL Electric Utilities
2 North 9th St
Allentown, PA 18101

Service Electric
15 J Campbell Collins Drive
Wilkes-Barre, PA 18702

Reading Blue Mountain & Northern Railroad
P. O. Box 218
Port Clinton, PA 19549

Dated this 16th day of MARCH, 2015

Deborah Delic

(Signature)

CERTIFICATE OF SERVICE

I, Verizon Pennsylvania LLC hereby certify that on MARCH 16, 2015 I served the foregoing application upon the parties listed below by first class mail, postage prepaid, addressed as follows:

PennDOT Bureau of Design
Mark D. Chappell, PE CHIEF
Keystone Building – 7th Floor
P. O. Box 3362
Harrisburg, PA 17105-3362

Ms. Gina M. D'Alfonso
Assistant Counsel in Charge
Dept. of Transportation
Office of Chief Personnel
P. O. Box 8212
9th Floor
Harrisburg, PA 171005-8212

Schuylkill County Board of Commissioners
401 North Second Street
Pottsville, PA 17901

McAdoo Borough
23 N. Hancock Street
McAdoo, PA 18237

PennDOT District 5-0
District Executive
1002 Hamilton Street
Allentown, PA 18101

Rodney D. Bender, PE Manger
Public Utility Commission
Rail Safety Division
P. O. Box 3265
Harrisburg, PA 17105

PPL Electric Utilities
2 North 9th St
Allentown, PA 18101

Service Electric
15 J Campbell Collins Drive
Wilkes-Barre, PA 18702

Reading Blue Mountain & Northern Railroad
P. O. Box 218
Port Clinton, PA 19549

Deborah Delia

U.S. DOT - CROSSING INVENTORY INFORMATION
As of 3/17/2015

Revision Date: 08/31/2013
Reason for Update: Change In Data

Reporting Agency: State
DOT Crossing Inventory No.: 361452F

Part I: Location and Classification information

Primary Operating Railroad: *Reading Blue Mountain & Northern Railroad Commision [RBMN]*

State: PENNSYLVANIA

Railroad Division or Region: READING

County: SCHUYLKILL

Railroad Subdivision or District: None

City/Municipality: Near MCADOO

Branch or Line Name: C&H BRANCH

Street/Road Name & Block #: BLAINE ST

RR Milepost: 0008.79

Highway Type & No.: SR 1009

Nearest RR Timetable Station: MCADOO

Parent RR: None

Line Segment: H 150.32

Crossing Owner: None

Do Other Railroads Operate a Separate Track at Crossing? No

Do Other Railroads Operate Over Your Track at Crossing? No

Crossing Type: Public

Public Access:

Crossing Purpose: Highway

Type of Train:

Crossing Position: At Grade

Type of Land Use: Residential

Avg Passenger Train Count Per Day: 0

Is there Adjacent Crossing with a Separate Number? No

Provide Crossing Number:

Quiet Zone: No

Latitude: 40.9010500

HSR Corridor ID:

Longitude: -75.9843800

Lat/Long Source: Actual

Railroad Use (Comments)

State Use (Comments)

A:

A: SR 1009 SEGMENT 0040

B:

B: RBMN

C:

C:

D:

D:

Narrative:

Narrative:

Emergency Notification Phone No. 610-562-4784 Railroad Contact: 610-562-2100 State Contact: 717-772-3079

Part II: Railroad Information

Total Day Thru Trains: 0 Total Night Thru Trains: 0 Less Than One Movement Per Day? No

Total Switching Trains: 0 Total Transit Trains: Total Trains Per week:

Year Of Train Count Data:

Maximum Timetable Speed: 10 Typical Speed Range Over Crossing: From 5 to 10 mph

Type and Count of Tracks: Main: 0 Siding: Yard: Transit: Industry:

Train Detection: DC

Track Signaled: No Event Recorder: Remote Health Monitoring:

U.S. DOT - CROSSING INVENTORY INFORMATION
(continued)

Revision Date: 08/31/2013

DOT Crossing Inventory No: 361452F

Part III: Highway or Pathway Traffic Control Device Information

Signs or Signals? **Yes**

Types of Passive Traffic Control Devices associated with the Crossing

Crossbucks Assemblies: 2	Stop Signs (R1-1): 0	Yield Signs (R1-2):
Low Ground Clearance Sign (W10-5): No		Advanced Warning Signs: Yes
Pavement Markings: Stop lines, RR		W10-1: W10-4:
Channelization Devices/Medians: None		W10-2: W10-11:
EXEMPT Sign (R15-3):		W10-3: W10-12:
ENS Sign Displayed (I-13): No		Count:
Other MUTCD Signs (Type):		Count:
Other MUTCD Signs (Type):		Count:
Other MUTCD Signs (Type):		Count:
Private Crossing Signs (if private):		LED Enhanced Signs:

Types of Train Activated Warning Devices at the Grade Crossing

Gates Arms:	Gate Configuration:			
Roadway: 0	Cantilevered (or Bridged) Flashing Light Structures:			Incandescent:
Pedestrian:	Over Traffic Lane: 0			LED:
	Not Over Traffic Lane: 0			
Mast Mounted Flashing lights: 2	Incandescent:	LED:	Back Lights Included:	Side Lights Included:
Total Count of Flashing Light Pairs: 4	Wayside Horn:	Installed on:		
Highway Traffic Signals Controlling Crossing: No	Installation Date of Current Active Warning Devices:			
Non-Train Active Warning:	Bells: 0			
Other Flashing Lights or Warning Devices: (count) 0	Type:			
Does Nearby Hwy Intersection have Traffic Signals: No	Hwy Traffic Signal Interconnection:			
Highway Traffic Signal Preemption:	Highway Traffic Pre-Signals:			
	Storage Distance:	Stop Line Distance:		
Highway Monitoring Devices:				

Part IV: Physical Characteristics

Traffic Lanes Crossing Railroad: Number of Lanes: **2**

Is Roadway/Pathway Paved? **Yes** Does Track Run Down a Street? **No** Is Crossing Illuminated? **No**

Crossing Surface: **Other**
Other (specify): **RAIL SEAL**

Installation Date: Width: Length:

Intersecting Roadway within 500 feet? **No** If Yes, Approximate Distance (Feet):

Smallest Crossing Angle: **60°-90°** Is Commercial Power Available? **Yes**

Part V: Public Highway Information

Highway System: **(03) Federal Aid, Not** Functional Classification of Road at Crossing: **(0) Rural** **(5) Major Collector**

Is Crossing on State Highway System? **Yes** Highway Speed Limit: **35** **Posted**

Linear Referencing System (LRS Route ID): LRS Milepost:

Annual Average Daily Traffic (AADT): Year **2012** AADT: **001762** Estimated Percent Trucks: **06**

Regularly Used by School Buses? **No** Average Number per Day: **0** Emergency Services Route: